

ULTRA-LOW HUMIDITY STORAGE CABINETS

McDry

PRODUCT BROCHURE



ERC Co., Ltd.

SEIKA



UL US
LISTED
28ET



ULTRA-LOW
HUMIDITY STORAGE
CABINETS 1%RH



Prevent your components from micro-cracking during reflow with proper Ultra-Low Humidity Storage.



Micro-cracking
(Popcorn Crack)



Conforms to IPC/JEDEC J-STD-033D and IPC-1601 Guidelines.

- * ESD safe design adheres to IEC-61340-5-1 (ESD) Standard.
- * Dehumidifies ICs to prevent micro-cracking and can be used as an alternative to baking.
- * All models maintain 1%RH.
- * Powerful moisture absorbent is utilized to eliminate the use of nitrogen.
- * Wide range of cabinets including UL/C models.

<http://www.mcdry.us>

Absorption and Dehumidification Data of IC Packages

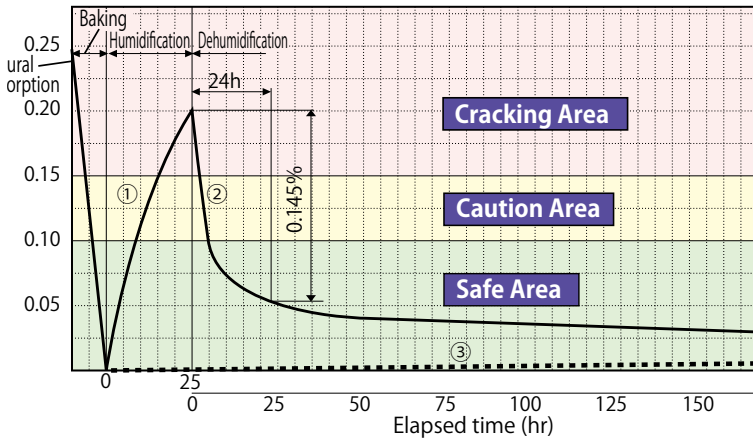

PBGA

Test Sample: PBGA

Pretreatment: Baked at 125°C, 24hrs.

Thickness 1.8 mm

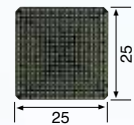

Conditions

1. Package is stored in simulated room conditions (30°C, 85% RH, 24 hours).
A controlled temperature, humidity chamber is used.
2. After Process 1 above has been completed, the package is stored in a low humidity storage case for 100 hrs at 5% RH.
3. After the baking process the package is stored in a low humidity storage case at 5% RH.

Low Humidity Storage of Thin Multi-Layer PCBs

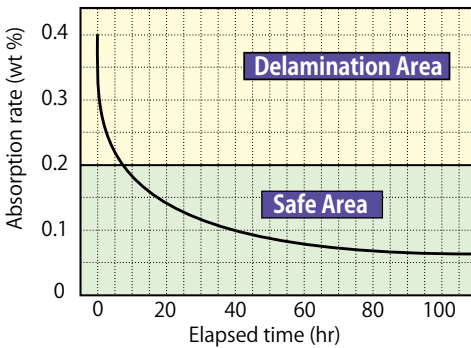

Multi-layered PCBs absorb moisture at a faster rate as they become thinner. Layer break off and blistering will occur during reflow if the moisture content of the PCB exceeds 0.2% (weight).

Test Sample: 6 layer Glass Epoxy PCB

Size: 50 x 100 x 1t (mm)

Pre-Treatment: Baked for 24 hours at 125°C

Humidification: Steamed for 2 hours

De-Humidification: Stored in McDry Cabinet at 5%RH

Data on Moisture Absorption and Dehumidification of Chip LEDs

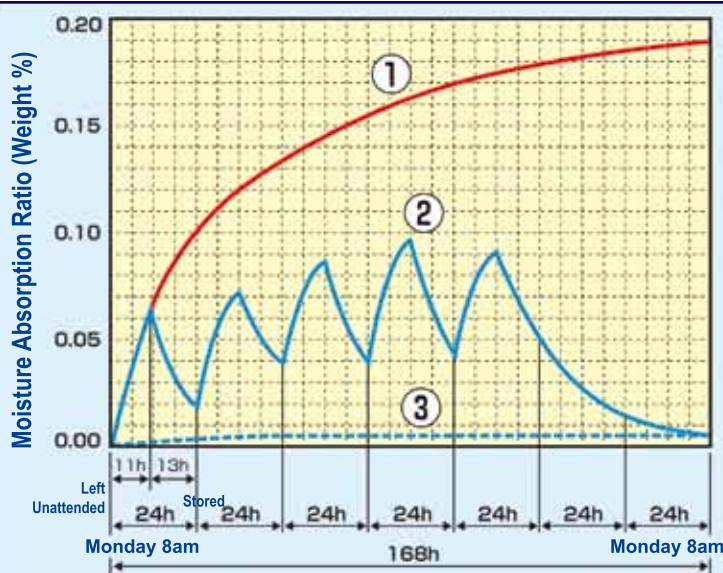

Experiment

Data on moisture absorption and dehumidification of chip LEDs

Example: LED3025 (3.0mm x 2.5mm x t1.3mm)

floor life 168h

Pretreatment: 48 hour-Baking Process at +60°C

(LED makers' baking guideline)

- ① Chip LED stored in ambient environment (30°C, 60% RH) for 168 hours.
- ② After 11 hours of storage in this environment, it was left for 13 hours in a dry box at <3% RH.
This process was repeated 5 times from Monday to Friday and left for 61 hours in a dry box at <3% RH.
- ③ After baking, the LED chip was stored in a dry cabinet capable of maintaining 3%RH.
(This is a similar condition with an LED chip that is stored in a dry cabinet right after opening a moisture barrier bag.)

MSL (IC Package, Chip LEDs) Device Management with McDry

Why do components require low humidity storage?

McDry Prevents Micro-Cracking of IC Packages and chip LEDs During Reflow.

The high temperatures involved in vapor phase or reflow passes cause the absorbed moisture to expand rapidly. Micro-cracking occurs in nearly 100% of IC packages and chip LEDs containing moisture during the reflow process. Occurring over an extended period of time, this can cause breakage of wiring and other problems. Micro-cracking can be prevented with storage and dehumidification of IC's and chip LEDs using McDry as well as resetting the floor life of components according to the IPC/JEDEC J-STD-033D.

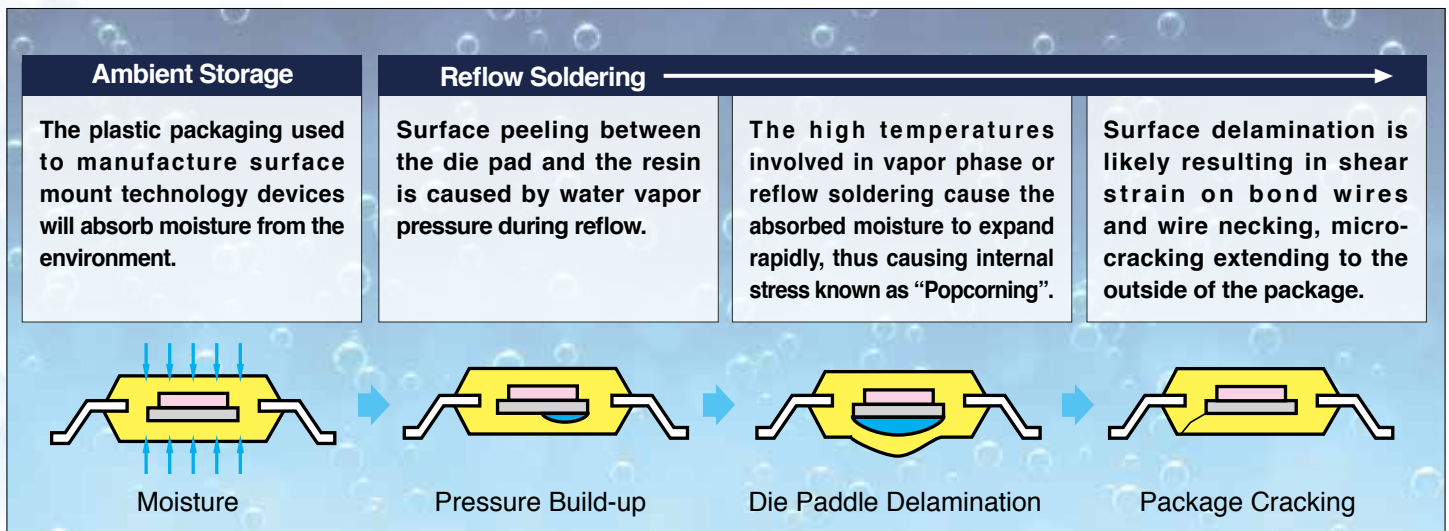
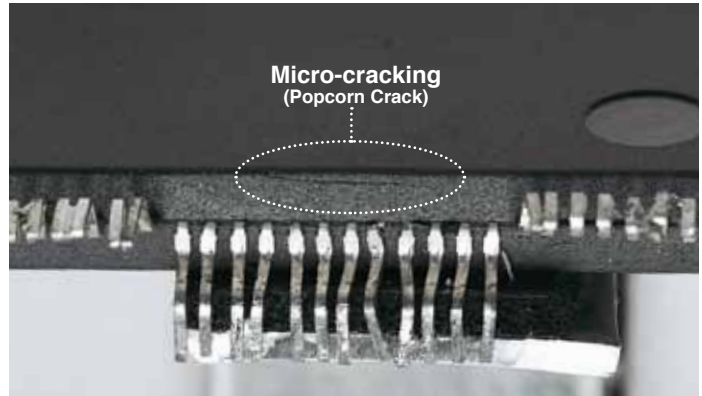

Protect Components with Dry Storage in McDry

When moisture-sensitive components are stored in a dry environment capable of maintaining 5% RH or less, the floor life will be indefinite according to the IPC/JEDEC J-STD 033D.

McDry Dry Storage Cabinets maintain ultra-low humidity levels under the recommended indefinite safe floor life guideline of dry storage at 5% RH or less.

For storing moisture-sensitive components and materials in the McDry cabinet, the floor life of the parts during the SMT assembly process. Simply place the MSL parts in McDry to maintain safe dry storage and remove them as required.

Moisture-Sensitivity Level (MSL) and Floor Life per J-STD-033D

Moisture Sensitivity Level	Floor Life(out of bag) at factory ambient < 30°C and / 60% RH or as stated
1	Unlimited at < 30°C / < 85%RH
2	1 year
2a	4 weeks
3	168 hours
4	72 hours
5	48 hours
5a	24 hours
6	Mandatory bake before use. After bake, must be reflowed within the time limit specified on the label.

McDry & DicksonOne / DXU-1001A / with Data Logger

Sample DicksonOne Data Chart with McDry



McDry

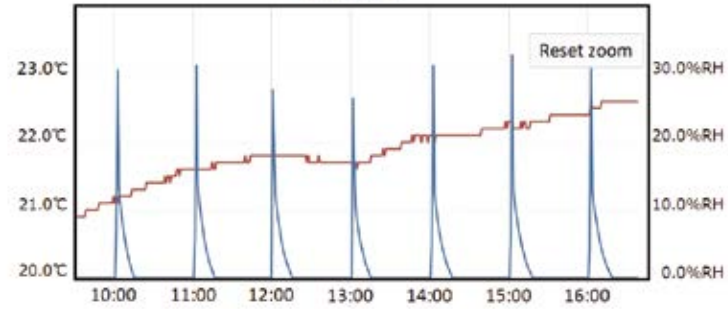

McDry cabinets can be monitored reliably with the DicksonOne temperature and humidity monitoring system.

Features of the DicksonOne includes:

1. Secure, cloud-based data storage.
2. Multiple unit monitoring.
3. Schedule recurring reports right to your in box.
4. Email, text and phone alerts when temperature or humidity is out of specification.

Opening-Closing Data of DXU-1001A

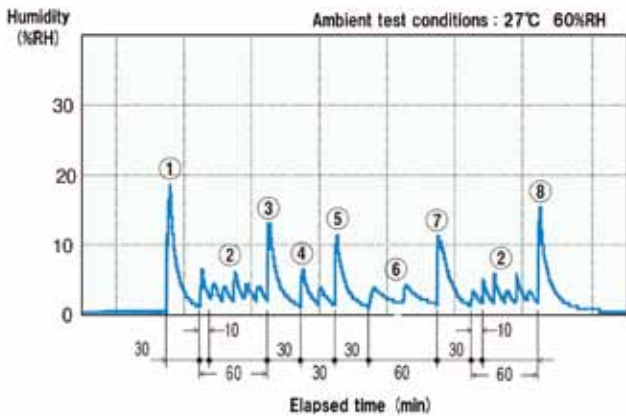

The Door opening place and time

- No. ① 2 doors (C,D) 2 min. open both
- No. ② 1 door (A,B,C,D,E,F) 15 sec. open
- No. ③ 2 doors (C,D) 1 min. open both
- No. ④ 1 door (D,F) 15 sec. open
- No. ⑤ 2 doors (C,D) 30 sec. open both
- No. ⑥ 1 door (C,E) 20 sec. open
- No. ⑦ 2 doors (A,B) 30 sec. open both
- No. ⑧ 2 doors (E,F) 1 min. open both

Humidity Data of McDry Cabinets

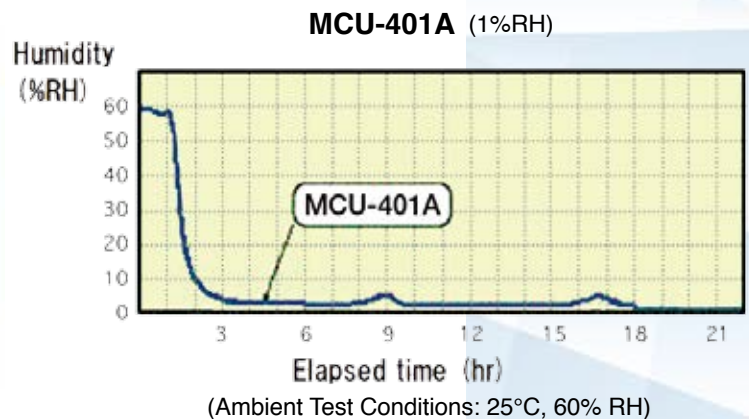
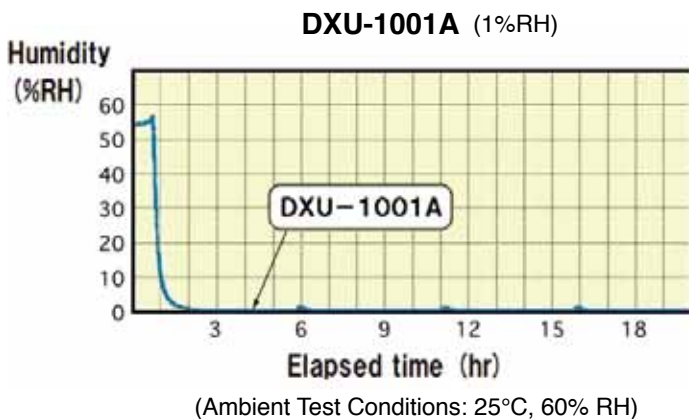

Manufactured for High Performance

McDRY



Locking doors that seal tightly.

Solid steel construction with ESD safe design.

Adjustable shelves (stainless steel available).

Digital RH meter

Drying Unit

Cabinet is grounded to prevent component damage due to static electricity.

ESD safe casters Standard for 501A,1001A,1002A type cabinets.

RH METER



Range

Humidity: 1~70%RH
Accuracy: ±3%RH

DRY UNIT



Features

1. Powerful zeolite desiccant eliminates the need for nitrogen.
2. Desiccant is automatically recycled and does not require replacement.

Dehumidifying Principle

Dehumidifying Principle

McDry Electronic Drying Storage Cases provide low humidity storage without the use of nitrogen. Humidity is removed from the cabinets by use of a powerful zeolite desiccant. The desiccant is automatically recycled with a heating mechanism and does not require replacement. Moisture absorbed by the zeolite desiccant is vaporized and released outside of the cabinet. Memory shaped metal is utilized for fail proof ventilation. Forced air flow convection system desiccates the entire cabinet with fan for optimal dehumidification to take place.

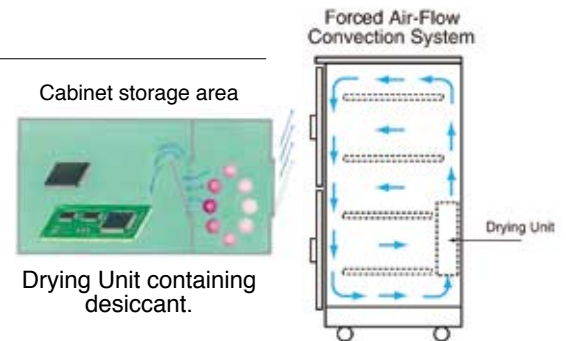

Handling and Storage Guidelines of IC Packages

Storing in 5% RH and 10% RH storage cabinets in accordance with IPC/JEDEC J-STD 033D

In accordance with IPC/JEDEC J-STD-033D, IC packages that have been removed from MBBs must be kept under a condition of 5% or 10% relative humidity to prevent components from absorbing moisture. However, during the mounting process, opening and closing of dry cabinet storage doors may occur frequently in order to remove and replace moisture-sensitive devices. This will allow ambient air to flow into the cabinet and may raise the RH level. To limit this from occurring and to keep the relative humidity inside of the cabinet below 5% or 10% as specified, a consistent, ultra-low humidity storage level is recommended. Therefore, the storage guidelines utilizing the McDry cabinet corresponding to the repetition of opening and closing of doors are as follows:

Model	RH level	Frequency of opening-closing of doors	Usage example
DXU models	1% RH	Once in approx. 10 – 20 mins.	<ol style="list-style-type: none"> 1. Ultra-low humidity storage of IC's for cabinets that are accessed frequently. 2. Storage of IC packages that require ultra-low humidity storage such as components with high MSL classifications.
MC models MCU models	1% RH	Once in approx. 0.5 – 2 hrs.	<ol style="list-style-type: none"> 1. Ultra-low humidity storage of IC's for cabinets that are not accessed frequently. 2. Long-term storage of IC packages and electrical components. 3. Storage of PCBs, etc.

MC Model / 1%RH

Door Opening / Closing: Once every 0.5 - 2hrs.



MC-1001A
43 cf (6-door type)



MC-1002A
43 cf (4-door type)

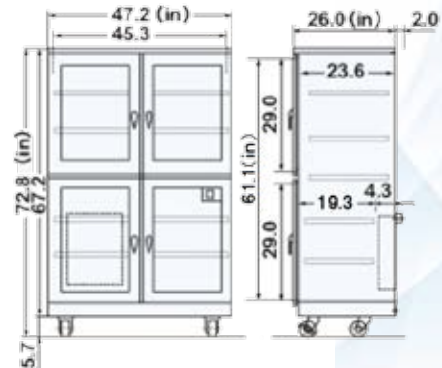
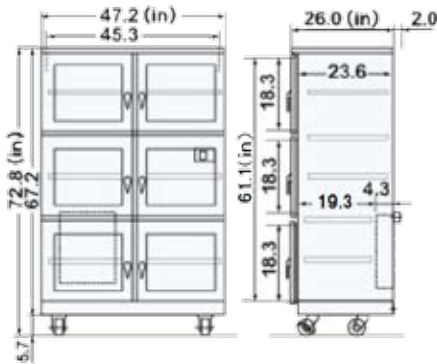

Specifications (Note: Specifications are subject to change due to product improvement.)

Item	Model	MC-1001A	MC-1002A
External Dimensions		47.2W x 26.0 D x 72.8H (in)	47.2W x 26.0 D x 72.8H (in)
Internal Dimensions		46.0W x 23.1D x 62.7H (in)	46.0W x 23.1D x 62.7H (in)
Capacity		Approx 43 Cu Feet (1200 Liters)	Approx 43 Cu Feet (1200 Liters)
Dry Unit		US-5000F	US-5000F
Material		High-grade steel construction with ESD-safe and Anti corrosion coating	High-grade steel construction with ESD-safe and Anti corrosion coating
Color		Silver	Silver
Doors (Magnetic)		6 Doors with glass windows	4 Doors with glass windows
Weight		Approx 419 lbs. (190 kgs.)	Approx 396 lbs. (180 kgs.)
Electrical Requirement		AC 120V (50/60Hz) 28W/h Max 350W	AC 120V (50/60Hz) 28W/h Max 350W
Accessories Included		5 shelves, Locks, RH meter, Caster, Ground terminal	5 shelves, Locks, RH meter, Caster, Ground terminal

Features:

1. Can maintain an RH level of 1%.
2. Equipped with a digital RH Meter.
3. Locking Doors.
4. Adjustable shelves.
5. Loading capacity 220 lbs. (100 kgs.)
6. Grounded to prevent static electricity.

DXU Mode / 1%RH Quick Dehumidification Model

Door Opening / Closing: Once every 10 - 20 min.



McDRY



McDRY



DXU-1001A
43 cf (6-door type)



DXU-1002A
43 cf (4-door type)



DXU-501A
22 cf (3-door type)

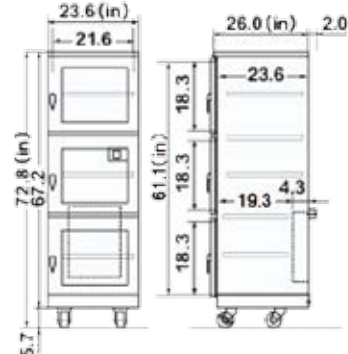
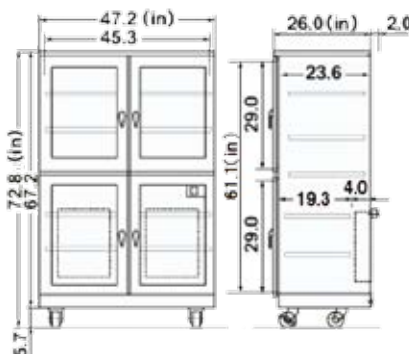
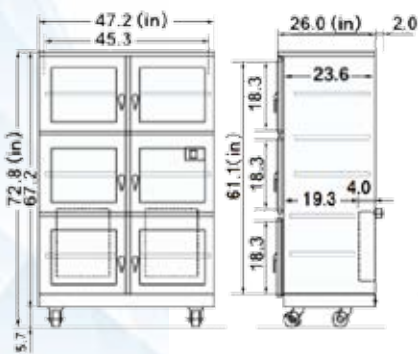

Specifications (Note: Specifications are subject to change due to product improvement.)

ITEM	MODEL	DXU-1001A	DXU-1002A	DXU-501A
External Dimensions		47.2W x 26.0D x 72.8H (in)	47.2W x 26.0D x 72.8H (in)	47.2W x 26.0D x 72.8H (in)
Internal Dimensions		46.0W x 23.1D x 62.7H (in)	46.0W x 23.1D x 62.7H (in)	23.0W x 23.6D x 63.2H (in)
Capacity		Approx 43 Cu Feet (1200 Liters)	Approx 43 Cu Feet (1200 Liters)	Approx 22 Cu Feet (600 Liters)
Dry Unit		USF-7200 x 2	USF-7200 x 2	US-5000F
Material		High-grade steel construction with ESD-safe and Anti corrosion coating	High-grade steel construction with ESD-safe and Anti corrosion coating	High-grade steel construction with ESD-safe and Anti corrosion coating
Color		Silver	Silver	Silver
Doors (Magnetic)		6 Doors with glass windows	4 Doors with glass window	3 Doors with glass windows
Weight		Approx 440 lbs. (200 kgs.)	Approx 419 lbs. (190 kgs.)	Approx 243 lbs. (110 kgs.)
Electrical Requirement		AC 120V (50/60Hz) 57W/h Max 500W	AC 120V (50/60Hz) 57W/h Max 500W	AC 120V (50/60Hz) 28W/h Max 350W
Accessories Included		5 shelves, Locks, RH meter, Caster, Ground terminal	5 shelves, Locks, RH meter, Caster, Ground terminal	5 shelves, Locks, RH meter, Caster, Ground terminal

Features:

1. Can maintain an RH level of 1%.
2. Equipped with a digital RH Meter.
3. Locking Doors.
4. Adjustable shelves.
5. Loading capacity 220 lbs. (100 Kgs)
6. Grounded to prevent static electricity.

MB Baking Model / 40-50°C / 1%RH Low Temperature / Low Humidity Bake-Out



MB-1001A
43 cf
(6-door type)



MB-301A
11 cf
(2-door type)

By utilizing low temperature and low humidity baking, this model conforms to the IPC-J-STD 033D specifications. It may be possible to reset the floor life of IC packages in tape and reel.

The versatile system also acts as a normal dry cabinet when not in baking mode.

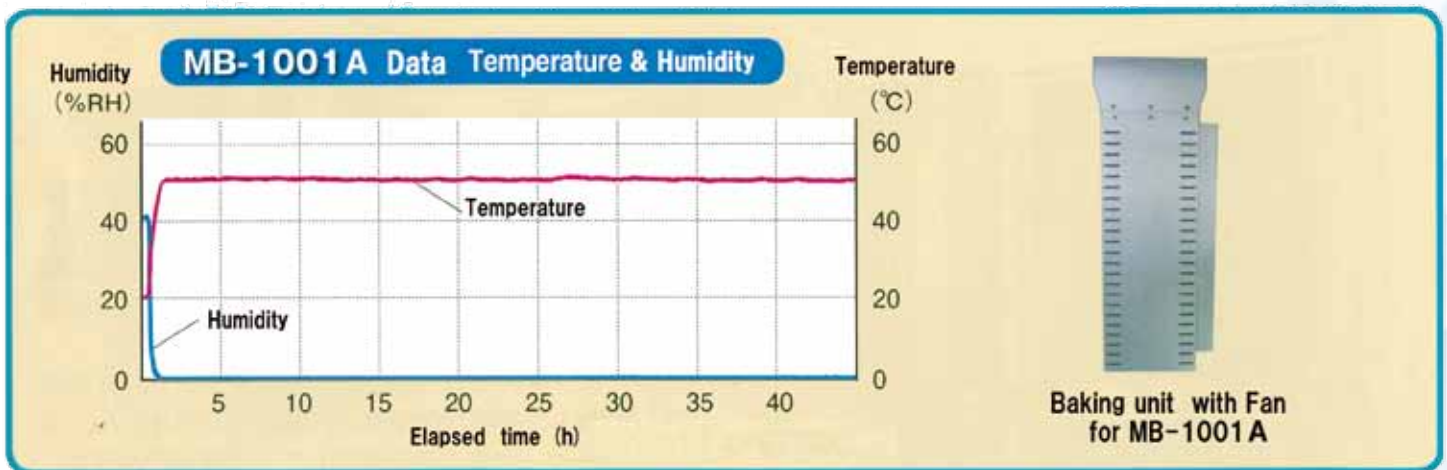

Specifications (Note: Specifications are subject to change due to product improvement.)

MODEL	MB-1001A	MB-301A
External Dimentions	49.0W x 30.3D x 78.1H (in)	20.7W x 25.6D x 54.9H (in)
Internal Dimentions	45.3W x 19.5D x 60.2H (in)	18.1W x 20.3D x 40.8H (in)
Capacity	Approx. 43 Cu Feet (1200 Liters)	Approx. 11 Cu Feet (310 Liters)
Drying Unit	USF-7200 X 2	USF-4000
Material	High-grade steel construction with ESD-safe and Anti corrosion coating	
Color	Silver	Ivory
Doors (Magnetic)	6 doors with glass windows	2 doors with glass windows
Weight	Approx. 440 lbs. (200 kgs.)	Approx. 154 lbs. (70 kgs.)
Electrical Requirement	AC120V (50/60Hz) MAX 1200W (Heating unit 660W)	AC120V (50/60Hz) MAX 650W (Heating unit 350W)
Accessories	5 Shelves, Locks, RH meter, Caster, Ground terminal	5 Shelves, Locks, RH meter, Caster, Ground terminal

Features:

1. Ultra-powerful rapid drying unit.
2. Digital humidity meter with larger display panel.
3. 1 MΩ ground terminal.
4. Shelf load capacity
MB-1001A: 220lbs.(100kgs.)
MB-301A: 110lbs.(50kgs)
5. Complies with the IPC/JEDEC.
6. Electrostatic discharge (ESD) complies with IEC 61340-5-1.

*MB model doesn't have cooling function.

MCU Model / 1%RH

Door Opening / Closing: Once every 0.5 - 2hrs



MCU-201A
4.8 cf
(1-door type)



MCU-301A
11 cf
(2-door type)



MCU-401A
14 cf
(3-door type)



MCU-340A
11 cf
(2-door type)



MCU-580A
18.5 cf
(2-door type)

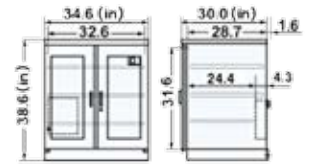
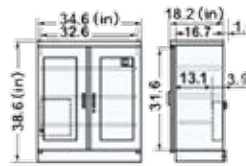
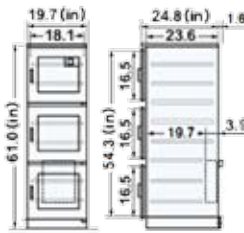
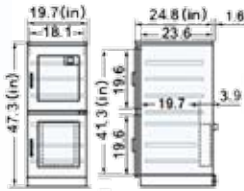
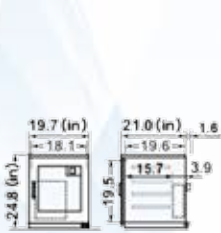

Features:

1. Can maintain an RH level of 1%.
2. Equipped with a digital RH Meter.
3. Locking Doors.
4. Adjustable shelves.
5. Loading capacity
MCU-201A, 301A, 401A, 340A, 580A:
110 lbs (50 kgs)
6. Grounded to prevent static electricity.

Specifications (Note: Specifications are subject to change due to product improvement.)

ITEM	MODEL	MCU-201A	MCU-301A	MCU-401A	MCU-340A	MCU-580A
External Dimensions		19.7W x 21.0D x 24.8H (in)	19.7W x 24.8D x 47.3H (in)	19.7W x 24.8D x 61.0H (in)	34.6W x 18.2D x 38.6H (in)	34.6W x 30.0D x 38.6H(in)
Internal Dimensions		18.9W x 19.6D x 21.5H (in)	18.9W x 23.6D x 43.2H (in)	18.9W x 23.6D x 56.2H (in)	33.9W x 16.7D x 33.1H (in)	34.0W x 28.7D x 33.0H(in)
Capacity		Approx 4.8 Cu Feet (135 Liters)	Approx 11 Cu Feet (310 Liters)	Approx 14 Cu Feet (400 Liters)	Approx 11 Cu Feet (300 Liters)	Approx 18.5 Cu Feet (520 Liters)
Dry Unit		USF-3200	USF-4000	USF-4000	USF-4000	US-5000F
Material		High-grade steel construction with ESD-safe and Anti corrosion coating	High-grade steel construction with ESD-safe and Anti corrosion coating	High-grade steel construction with ESD-safe and Anti corrosion coating	High-grade steel construction with ESD-safe and Anti corrosion coating	High-grade steel construction with ESD-safe and Anti corrosion coating
Color		Ivory	Ivory	Ivory	Ivory	Silver
Doors (Magnetic)		1 Door with glass window	2 Doors with glass windows	3 Doors with glass windows	2 Doors with glass windows	2 Doors with glass windows
Weight		Approx 66 lbs. (30 kgs.)	Approx 132 lbs. (60 kgs)	Approx 154 lbs. (70 kgs.)	Approx 128 lbs. (58 kgs.)	Approx 176 lbs. (80 kgs.)
Electrical Requirement		AC 120V (50/60Hz) 20W/h Max 155W	AC 120V (50/60Hz) 25W/h Max 240W	AC 120V (50/60Hz) 25W/h Max 240W	AC 120V (50/60Hz) 25W/h Max 240W	AC 120V (50/60Hz) 28W/h Max 350W
Accessories Included		4 shelves, Locks, RH meter, Ground terminal	8 shelves, Locks, RH meter, Ground terminal	8 shelves, Locks, RH meter, Ground terminal	3 shelves, Locks, RH meter, Ground terminal	3 shelves, Locks, RH meter, Ground terminal

Feeder Storage Cabinet/ 1%RH



DXU-580SF
(2-door type)
Electric Tape Feeder
Storage



DXU-580AF
(2-door type)
Mechanical Tape Feeder
Storage

Specifications (Note: Specifications are subject to change due to product improvement.)

ITEM	MODEL	DXU-580SF	DXU-580AF
External Dimentions		34.6W x 47.2D x 52.1H (in)	34.6W x 47.2D x 63.0H (in)
Internal Dimentions		32.7W x 43.3D x 31.1H (in)	32.7W x 43.3D x 37.6H (in)
Capacity		Approx. 31.8 Cu Feet (900 Liters)	Approx. 32.9 Cu Feet (932 Liters)
Drying Unit		US-5000F X 2	
Material		High-grade steel construction with ESD-safe and Anti corrosion coating	
Color		Silver	
Doors (Magnetic)		2 doors with glass windows	
Weight		Approx. 440 lbs. (200 kgs.)	Approx. 529 lbs. (240 kgs.)
Electrical Requirement		AC120V (50/60Hz) 56W/h (MAX 700W)	
Accessories		Locks, RH meter, Caster, Ground terminal	

Feeder Cart Storage cabinet/ 1%RH



DXU-2900
103 cf
(2-door type)

Feeder Cart
(Storage Item)



Features:

1. The entire feeder cart can be stored.
2. Feeder cart storage max prevent feeder connection errors and reduce down time.
3. Also features additional shelves for trays allowing and tape reels to be stored along with the feeder wagon.

Specifications (Note: Specifications are subject to change due to product improvement.)

ITEM	MODEL	DXU-2900
External Dimentions		51.2W x 49.4D x 77.6H (in)
Internal Dimentions		44.9W x 39.4D x 70.9H (in)
Capacity		Approx. 103 Cu Feet (2900 Liters)
Drying Unit		USK-6000 X 3
Material		High-grade steel construction with ESD-safe and Anti corrosion coating
Color		Silver
Doors (Magnetic)		2 doors with glass windows
Weight		Approx. 1168 lbs. (530 kgs.)
Electrical Requirement		AC120V (50/60Hz) 135W/h (MAX 700W)
Accessories		1 shelf, Locks, RH meter

Feeder Bank & Large Depth Cabinet / 1%RH



DXU-1002-1000A
67.1 cf
(2-door type)



Tape feeder

Tape feeder with the tape reels can be stored in these cabinets.

DXU-1002LA
56.5 cf
(4-door type)

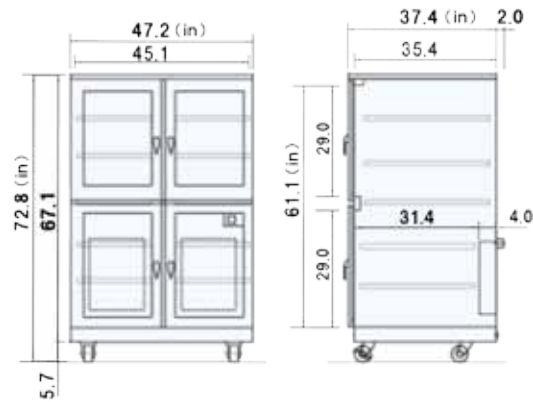
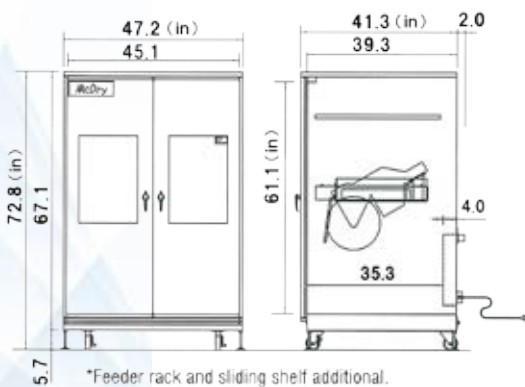









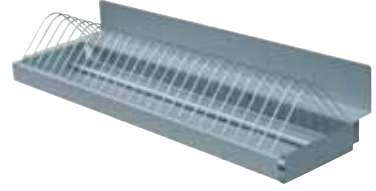

Specifications (Note: Specifications are subject to change due to product improvement.)

ITEM	MODEL	DXU-1002-1000A	DXU-1002LA
External Dimensions		47.2W x 41.3D x 72.8H (in)	47.2W x 37.4D x 72.8H (in)
Internal Dimensions		46.0W x 38.6D x 62.7H (in)	46.0W x 34.7D x 62.7H (in)
Capacity		Approx 67.1 Cu Feet (1900 Liters)	Approx 56.5 Cu Feet (1600 Liters)
Dry Unit		USF-7200 x 2	USF-7200 x 2
Material		High-grade steel construction with ESD-safe and Anti corrosion coating	High-grade steel construction with ESD-safe and Anti corrosion coating
Color		Silver	Silver
Doors (Magnetic)		2 Doors with glass windows	4 Doors with glass windows
Weight		Approx 594 lbs. (270 kgs.)	Approx 551 lbs. (250 kgs.)
Electrical Requirement		AC 120V (50/60Hz) 57 W/n Max 500W	AC 120V (50/60Hz) 57 W/n Max 500W
Accessories Included		5 shelves, Locks, RH meter, Caster, Ground terminal	5 shelves, Locks, RH meter, Caster, Ground terminal

Features:

1. Can maintain an RH level of 1%.
2. Equipped with a digital RH Meter.
3. Locking Doors.
4. Shelves are adjustable and can hold 220lbs. (100 kgs)
5. Grounded to prevent static electricity.

Optional Parts for McDry

Hygrometer with alarm	Data logger	Reel rack
<p>Alarm lamp is triggered when the humidity exceeds the set parameters.</p> 	<p>Humidity data is recorded at all times.</p> 	<p>A variety of tape reels can be stored efficiently.</p> 
N2 socket	Flow meter	Shelves (Steel Stainless)
<p>Nitrogen purge is available.</p> 	<p>This flow meter can measure and control N2 flow</p> 	<p>Additional shelves can be purchased for all models. Stainless steel shelves are also available.</p> 
ESD Caster Wheels	Adjustor	Sliding shelf
<p>ESD-safe casters are available for the MCU type as an option. (DXU type equipped with this caster as standard)</p> 	<p>Adjusts the height of the cabinet.</p> 	<p>With the sliding shelf, picking up the stored items become easy.</p> 
Tower Light	Wrist strap	
<p>The tower light flashes when humidity goes over the level set using the hygrometer with alarm.</p> 	<p>Promptly diffuses static electricity away from the cabinet.</p> 	



SEIKA MACHINERY, INC.

21241 S. Western Ave, Suite 140, Torrance, CA 90501
TEL. 310-540-7310 FAX. 310-540-7930

VISIT OUR WEB SITE
www.seikausa.com

Agent



ERC Co., Ltd.

#402 OHYA BILD. 3-16-11 SAGAMIOHNO, MINAMI-KU,
SAGAMIHARA-shi, KANAGAWA, 252-0303 JAPAN
TEL:+81-42-749-9751 FAX:+81-42-744-2521
www.mcdry.us